

TESTING FIBRE REINFORCED CONCRETE IN AN INVERTED T-BEAM

Matti Lanu

Seppo Huovinen

Rakenteiden Mekaniikka, Vol. 28
No 3, 1995, s. 25 - 43

ABSTRACT

In this research the main focus is on the analysis of short dispersed steel fibres in a cement-based matrix. Tests and analyses were performed in order to verify the feasibility of fibre reinforcement in an inverted T-beam. When considering fibre reinforced concrete as a load-bearing structural material, the main interest lies on the post-crack tensile strength of the fibre composite. This post-crack strength gives the ductility, impact strength and beneficial cracking behaviour. This design and analysis tasks can be solved with a law-of-mixtures type of approach. This way some simple equation can be constructed. Tests are needed to determine the effects of different fibre types and concrete mix. The calculation methods presented and applied here give a reliable estimation as compared with test results.

INTRODUCTION

The hollow core slab is the leading product in Finland when it is question of prefabricated floor slabs. In modern office buildings they are usually supported by steel beams (THQ), by steel-concrete composite beams or by prestressed concrete beams. To reduce the structural height, the slabs are often placed on the lower flange of the beam in such a way that the main part of the beam is inside the height of the slab.

One of the prestressed concrete beam types is the so-called "Inverted T-beam", which describes its form well.

The flange of the inverted T-beam has to be reinforced, because the ends of the slabs rest on the flanges. The aim of the research was to study the possibility to use fibre reinforced concrete in the flanges, instead of the conventional reinforcement.

TEST STRUCTURES

To verify the design assumptions, the load-carrying capacity of the flange was determined with tests. The specimens were 1.2 m long simply supported beams. The flange was cut near the support in order to lead all the stresses to the web of the beam. The load was distributed to both flanges with steel parts. Displacements were measured in the middle span and near supports both on the centre line and on the edge line of the flange. The dimensions of the test beams and test arrangements are presented in the next figure.

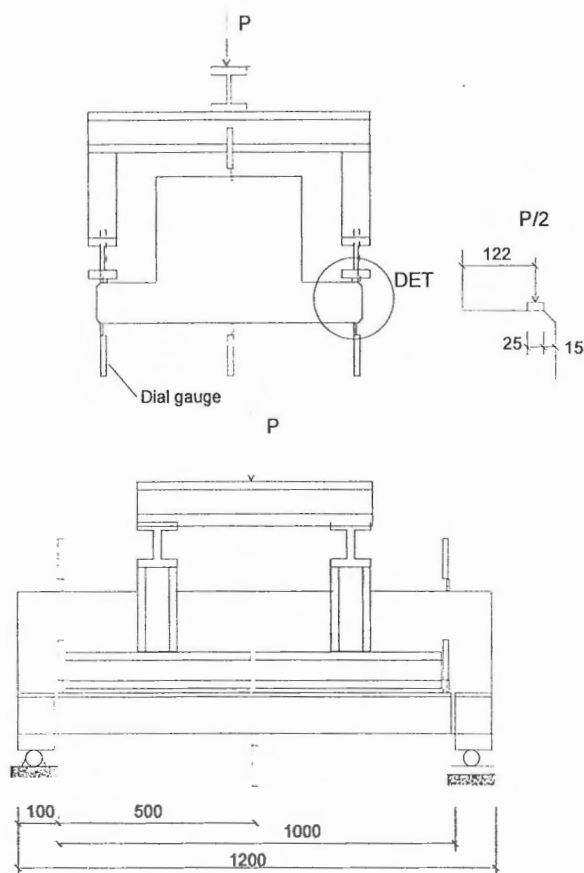

Fig. 1. Test arrangements

There were five different types of reinforcement in the test beams. One of the beam types contained normal stirrups. The other four beam types contained only main bars and varying amounts of fibres. The test for each type was performed on three beams in order to get information about the deviation of capacity.

The test structures were cast in VTT. Prestressing tendons that are used in normal production were replaced with same number of rebars. After casting the beams were stored for one day under a plastic film. Demoulding took place on the second or third day and loading after one week.

The cross-sections of the beams are shown in the next figure, and the amount of reinforcement in the next table.

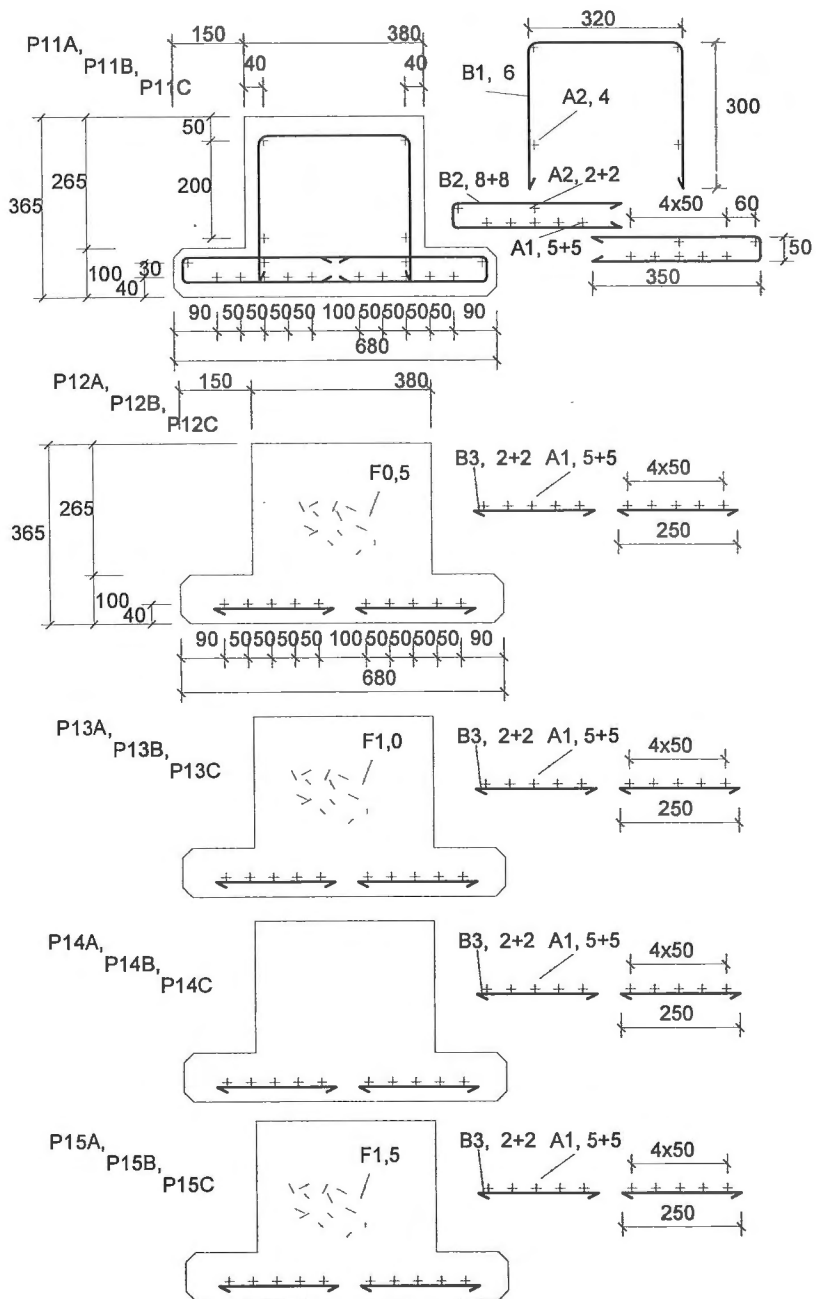

Fig. 2. Cross-sections of the beams.

Table 1. Quantities of materials in the test beams.

Beam symbols P11A, P11B, P11C						
Rebars and fibres	symbol	steel grade	φ mm	bar length mm	number of bars pcs.	bar weight kg
Rebars	A1	B500K	12	1200	10	10.6
Rebars	A2	B500K	10	1200	8	5.9
Stirrups; web	B1	B500K	8	300 + 320 + 300 = 920	6	2.2
Stirrups; flange	B2	B500K	8	350 + 50 + 350 = 750	16	4.7
TOTAL						23.4 kg

Beam symbols P12A, P12B, P12C						
Rebars and fibres	symbol	steel grade	φ mm	bar & fibre length mm	bar & fibre number / quantity pcs. / vol%	bar & fibre weight kg
Rebars	A1	B500K	12	1200	10	10.6
Rebars	B3	B500K	10	250	4	0.6
Fibres; Dramix	F0,5	ZP	0.5	50	0.5	7.9
TOTAL						19.1 kg

Beam symbols P13A, P13B, P13C						
Rebars and fibres	symbol	steel grade	φ mm	bar & fibre length mm	bar & fibre number/ quantity pcs. / vol%	bar & fibre weight kg
Rebars	A1	B500K	12	1200	10	10.6
Rebars	B3	B500K	10	250	4	0.6
Fibres; Dramix	F1,0	ZP	0.5	50	1.0	15.8
TOTAL						27.0 kg

Beam symbols P14A, P14B, P14C						
Rebars and fibres	symbol	steel grade	φ mm	bar length mm	number of bars pcs.	bar weight kg
Rebars	A1	B500K	12	1200	10	10.6
Rebars	B3	B500K	10	250	4	0.6
TOTAL						11.2 kg

Beam symbols P15A, P15B, P15C						
Rebars and fibres	symbol	steel grade	φ mm	bar & fibre length mm	bar & fibre number/ quantity pcs. / vol%	bar & fibre weight kg
Rebars	A1	B500K	12	1200	10	10.6
Rebars	B3	B500K	10	250	4	0.6
Fibres; Dramix	F1,5	ZP	0.5	50	1.5	23.6
TOTAL						34.8 kg

CONCRETE MATERIALS USED IN THE TEST STRUCTURES

The concrete used was normal concrete and the mixture was kept constant while the fibre content was varied. The mix proportions of the concrete is presented in the next table.

Table 2. Concrete mixes used in the tests.

MIX	Mix symbols Beam symbols	L00 P11, P14 kg/m ³	L05 P12 kg/m ³	L10 P13 kg/m ³	L15 P15 kg/m ³
Binding agents					
	(c) Portland P40/3	390	390	390	390
	(s) silica	43	43	43	43
	Binding agents TOTAL	433	433	433	433
Aggregate					
	filler <0,125	133	131	131	131
	0,1-0,6 mm	266	263	263	262
	0,5-1,2 mm	266	263	263	262
	1-2 mm	266	263	263	262
	2-3 mm	398	394	394	393
	3-5 mm	398	394	394	393
	5-10 mm	159	158	158	157
	(a) Aggregate TOTAL	1886	1866	1866	1860
	(w) Water	132	140	140	139
	Water cement ratio (w + 0.6add)/(c + s)	0.34	0.35	0.35	0.36
	Aggregate cement ratio a/(c + s)	4.39	4.31	4.31	4.30
Admixtures					
	(add) Scancem SP 62	22	22	22	25
Steel fibres					
	Dramix ZC 50/.50 vol. %		39 0.5	78 1.0	117 1.5
	TOTAL kg/m ³	2473	2500	2539	2574

Basic properties of the fresh concrete were determined only with concrete without fibres and with a fibre content of 0.5 per cent by volume. Mechanical properties were determined either with casted prisms or with drilled cylinders from loaded structures. The results are shown in the next table.

Table 3. Properties of concrete used in tests.

METHOD	PROPERTIES	Mix symbols	L00	L05	L10	L15
		Beam symbols	P11, P14	P12	P13	P15
		Symbol				
SFS 5284 ¹	Slump test mm		19	23	-	-
SFS 5287 ²	Air content %		3.8	9.0	-	-
SFS 5288 ³	Density kg/m ³		2406	2307	-	-
ASTM C 1018 - 92	Flexural strength MPa prisms 100x100x500 average of 3 results	f_{cbu}	6.68	5.66	9.36	14.84 (2 results)
	First crack MPa	f_{cbr}	-	4.99	6.68	8.2
	Toughness index	I_5	-	3.97	4.22	4.99
		I_{10}	-	7.43	8.73	10.88
		I_{20}	-	15.05	16.63	24.98
SFS 4474 ⁴	Compressive strength MPa $\phi = 75$ mm, h = 75 mm average of 6 results	f_{ccu}	91.2	65.6	72.8	101.2
SFS 5443 ⁵	Tensile splitting strength MPa $\phi = 100$ mm, h = 100 mm average of 6 results	f_{csp}	5.13	4.52	6.63	9.57
SFS 5445	Tensile strength MPa $\phi = 75$ mm, h = 75 mm average of 6 results	f_{ctu}	4.8	3.9	3.7	4.6

If we calculate the ratio between direct tensile strength f_{ctu} and flexural strength f_{cbu} , we obtain the following values:

$$\text{L05, (fibre content 0.5\%): } f_{cbu} = 1.45 f_{ctu}$$

$$\text{L10, (fibre content 1.0\%): } f_{cbu} = 2.53 f_{ctu}$$

$$\text{L15, (fibre content 1.5\%): } f_{cbu} = 3.23 f_{ctu}$$

The values above indicate that a fibre content of 0.5 per cent by volume does not give much ductility. It can be confirmed by structural test results. Also it is clear that direct tensile strength is underestimated due to the difficult test arrangements. The values agree rather well with the range of theoretical values.

¹ Based on the international standard ISO 4109

² Based on the international standard ISO 4848

³ Based on the international standard ISO 6276

⁴ Based on the international standard ISO 4012

⁵ Based on the international standard ISO 4108

The material properties are summarized in the next two figures.

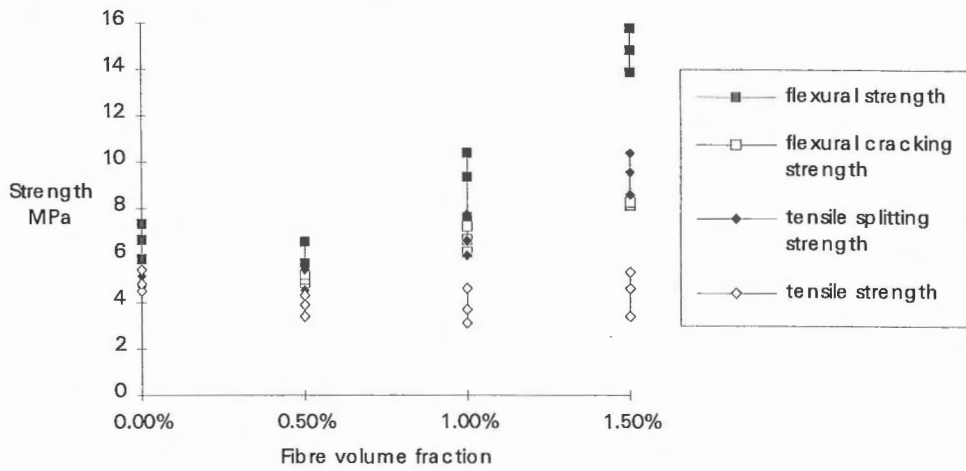

Fig. 3. Determined strength values as a function of the fibre content; the minimum, maximum and average values are presented.

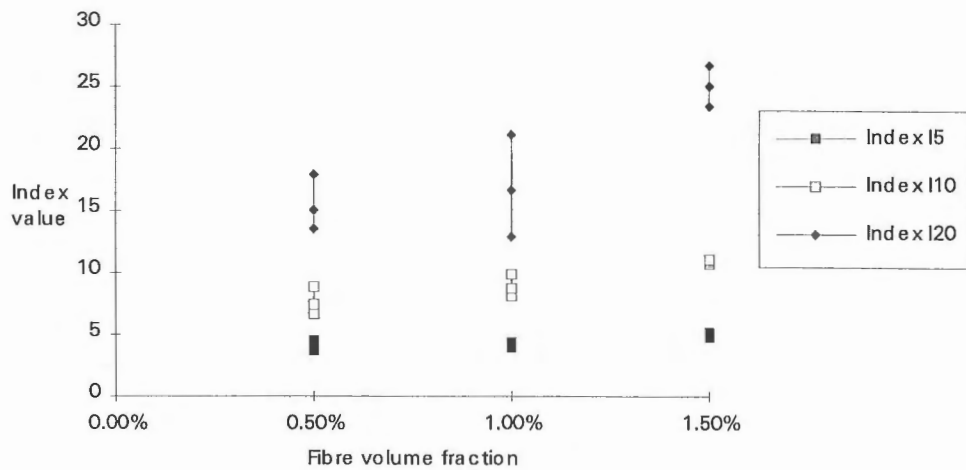

Fig. 4. Toughness index values (I_5 , I_{10} , I_{20}) as a function of the fibre content; the minimum, maximum and average values are presented.

TEST RESULTS AND ANALYSIS

Load-deflection curves are presented in the next five figures.

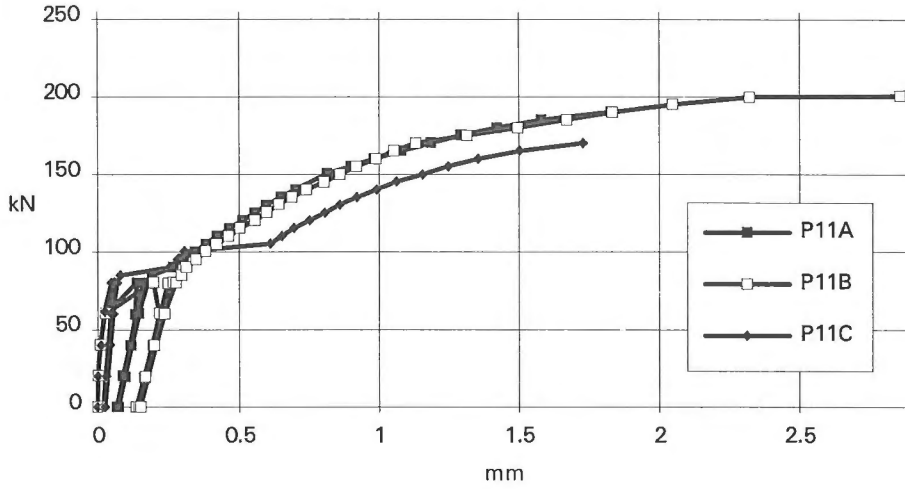

Fig. 5. Average deflections of flange; beam P11A...C with normal stirrups.

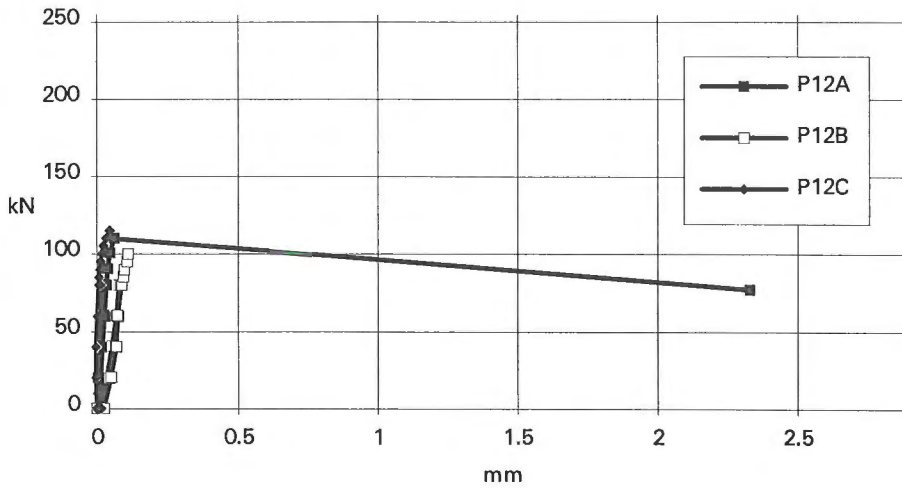

Fig. 6. Average deflections of flange; beam P12A...C with a fibre content of 0.5 %.

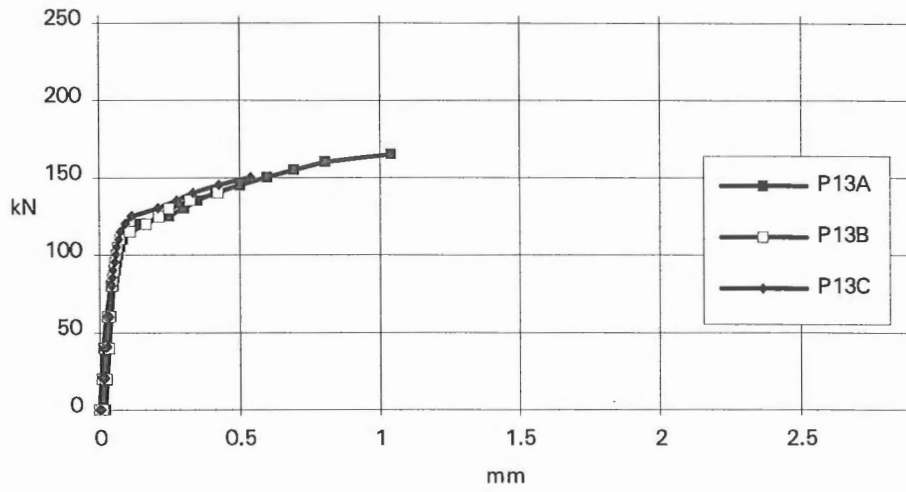

Fig. 7. Average deflections of flange; beam P13A...C with a fibre content of 1 %.

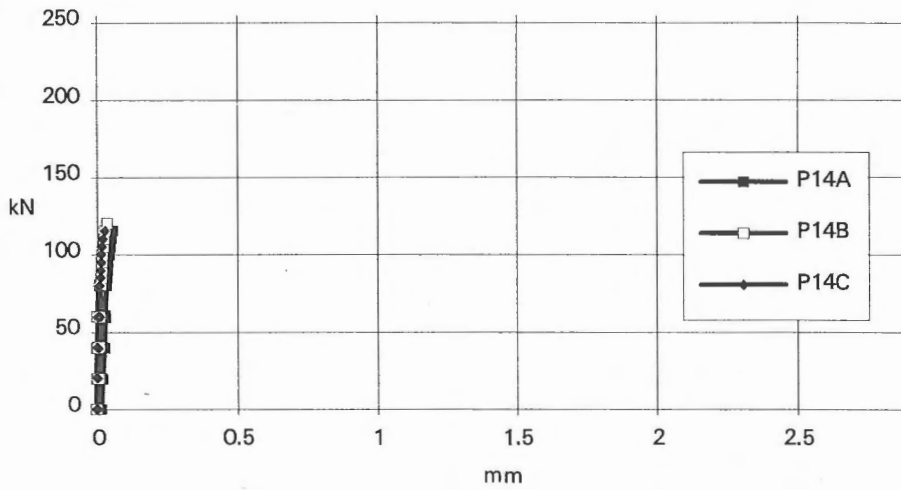

Fig. 8. Average deflections of flange; beam P14A...C with main bars only.

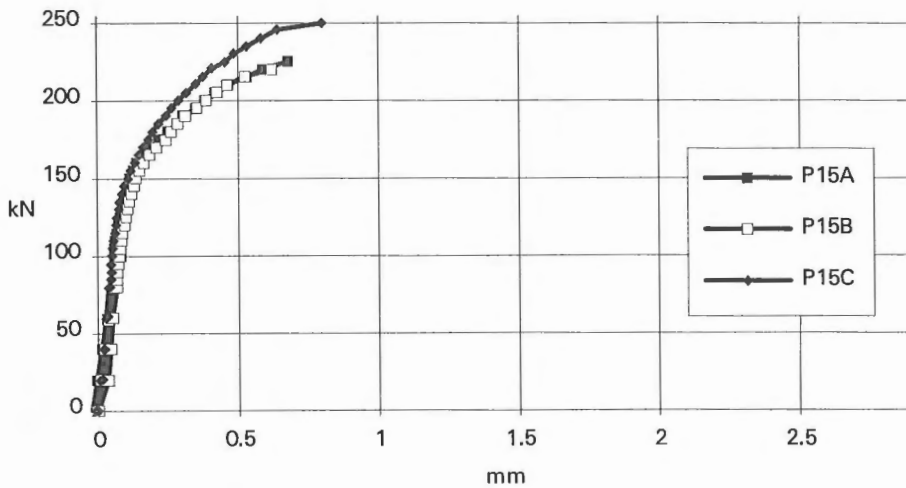

Fig. 9. Average deflections of flange; beam P15A...C with a fibre content of 1.5 %.

A summary of the beam test results is presented in the next figure as a function of the total amount of reinforcement steel (rebars and fibres) in the test structure.

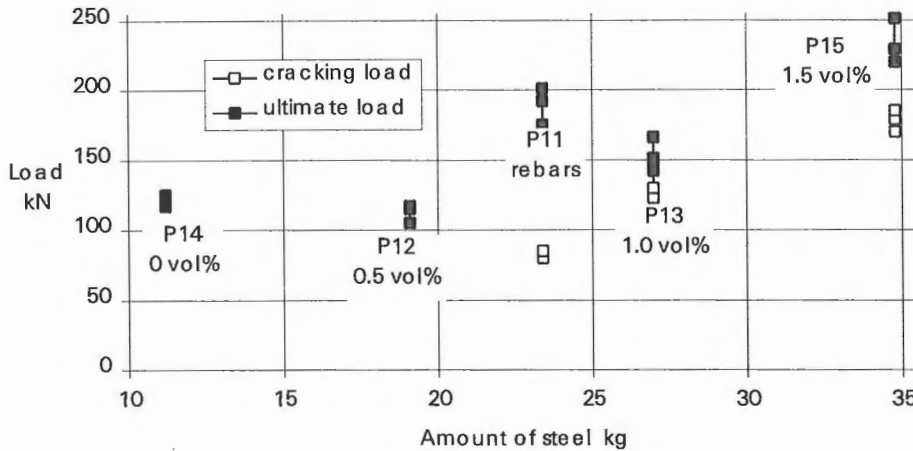

Fig. 10. Beam test results as a function of the total amount of reinforcement steel.

A flange with normal shear reinforcement collapses when the reinforcement yields or if the anchorage of the stirrups is insufficient. If fibre reinforcement is used, the tensile strength of the concrete is critical. The dimensioning of the flange in the ultimate state can

be made according to the cases illustrated in the next figure. The cracking load is calculated by assuming the linear elastic stress distribution.

The cracking load P_{cr} and the ultimate load P_u of a normally reinforced flange is calculated using the following equations:

$$\frac{1}{2}P_{cr} = \frac{f_{ctu}bh^2}{6a_l} \quad (1)$$

$$\frac{1}{2}P_u = \frac{7}{8a_l}f_{sy}A_s d \quad (2)$$

The following equations are used in the case of fibre reinforced concrete. The cracking load P_{cr} is estimated with the equation:

$$\frac{1}{2}P_{cr} = \frac{f_{ctu}bh^2}{6a_l} \quad (3)$$

The ultimate capacity P_u of a fibre reinforced flange is estimated with next two equations. The first one can be used when the height of the compression zone is 0.25 times the total height and the compressive stresses are in the elastic range. This is used, for example, by Hannant /3/:

$$\frac{1}{2}P_u = \frac{bh^2}{2a_l} \frac{13}{32} AV_f \frac{l_f}{d_f} f_\tau \quad (4)$$

The second alternative is the case where both the compression and the tensile zone are modelled with rectangular stress blocks; this is suggested, for instance, by Lim et al. /4/:

$$\frac{1}{2}P_u \approx \frac{bh^2}{2a_l} \left(1 - \frac{AV_f \frac{l_f}{d_f} f_\tau}{af_{fcu} + AV_f \frac{l_f}{d_f} f_\tau} \right) AV_f \frac{l_f}{d_f} f_\tau \quad (5)$$

Note that often $f_{ctu} > f_{fcu} \approx AV_f \frac{l_f}{d_f} f_\tau$

The ultimate bending capacity P_u can be estimated using the flexural strength f_{fcu} with the equation /6/, /1/:

$$\frac{1}{2}P_u = \frac{f_{fcbu}bh^2}{6a_l}; f_{fcbu} = \begin{cases} f_{fcbcr}R_{5.10} \\ f_{fcbcr}R_{10.20} \end{cases} \quad (6)$$

The cracking loads P_{cr} and the ultimate capacity P_u are presented in the next table together with the estimated values, which were calculated using average values of the determined material properties. Equation numbers are reported in the table. The constant values and factors used in the calculations are:

a_l is	122 mm
h	100 mm
d	75 mm
b	1000 mm
d_f	0.5 mm
l_f	50 mm
f_τ	4.8 MPa
f_{ctu}	4.8 MPa
A_s	402 mm ²
f_{sy}	500 MPa
a	0.9 in equation (5)
A	is 0.4 in equation (5) and 0.95 in equation (4)

The value of f_τ is chosen to be the same as the direct tensile strength of plain concrete. The rest of the values vary according to the materials.

Table 4. Comparison of test results with calculated values

Tests Cracking load P_{cr} kN	A				average kN	Calculations			
	A	B	C	average kN		eq (1)	eq (3)	eq (5)	eq (6)
P11	85	80	80	82	131				
P12	-	-	-	-			(107)		
P13	150	123	130	134			101		
P14	-	-	-	-			(131)		
P15	179	170	185	178			126		
Ultimate load P_u kN	A	B	C	average kN	eq (2)	eq (4)	eq (5)	eq (6)	
P11	192	201	175	189	162	-	-	-	
P12	115	105	117	112	-	(107) ⁶	(107)	94	
P13	166	142	151	153	-	152	153	165	
P14	119	125	117	120	-	(131) ⁷	(131)	-	
P15	229	220	251	233	-	228	229	264	

⁶ The estimated cracking load is greater than the load at the post cracked stage, so the cracking load is presented here as the ultimate load.

⁷ The fibre content is here 0 per cent by volume so the cracking load is the same as the ultimate load.

It can be stated that both equations (4) and (5) give equal results. However, it can be concluded that equation (5) is more suitable for this case.

As mentioned earlier, factor A has different values in these two equations. In theory factor A should be in the range of 0.08 to 0.5 in this type of application. This is because factor A depends on both the fibre orientation factor η_ϕ and the fibre bond efficiency factor η_l and they both are far below 1.0. The values for these factors in a random 3-dimensional case are listed below [2/ 13/]:

$$\eta_\phi = \frac{1}{6} \dots \frac{1}{2} \quad (7)$$

$$\text{when } l_f \ll l_{crit}, \text{ then } \frac{1}{4} \frac{l_f}{l_{crit}} < \eta_l < \frac{1}{2} \frac{l_f}{l_{crit}} \quad (8)$$

$$\text{where } l_{crit} = \frac{d_f f_{fu}}{2 f_\tau}$$

The following equation can be written to express the tensile strength f_{fctu} in the cracked stage.

$$f_{fctu} \approx \eta_\phi \eta_l f_{fu} V_f = A V_f \frac{l_f}{d_f} f_\tau = \left(\frac{1}{12} \dots \frac{1}{2} \right) V_f \frac{l_f}{d_f} f_\tau \quad (9)$$

Values for f_{fctu} are reported in Table 5. The values are compared with the modulus-of-rupture values obtained from the test results according to the following expression:

$$f_{fcbu} = \frac{6 a_l}{b h^2} \frac{P_u}{2} \quad (10)$$

Table 5. Tensile strength of fibre reinforced concrete f_{fctu} (eq (9)) used in previous calculations and comparison with modulus-of-rupture values f_{fcbu} (eq (10)).

Fibre content		0.5%	1.0%	1.5%
Beam symbols		P12	P13	P15
from test results	f_{fcbu} MPa	(4.10) ⁸	5.60	8.53
in eq (4) $A = 0.95$	f_{fctu} MPa	2.28	4.56	6.84
	f_{fcbu}/f_{fctu}	(1.80)	1.23	1.25
in eq (5) $A = 0.4$	f_{fctu} MPa	0.96	1.92	2.88
	f_{fcbu}/f_{fctu}	(4.27)	2.92	2.96

The ratio f_{fcbu}/f_{fctu} should be about 1.5 in plain concrete /5/ and its theoretical maximum is 3.0. Bentur & Mindess /2/ suggest the value 2.44. So the latter equation (5) represents well the situation at the ultimate state with fibre contents of 1% and 1.5%.

From test the results it can be seen that a fibre content of 0.5% is too low to act as a structural reinforcement. This can be verified by calculating the theoretical critical fibre volume in bending with the following equations /2/, /3/:

$$V_{crit}^{tension} = (2 \dots 12) \frac{f_{ctu}}{f_c} \frac{d_f}{l_f} \approx 2\% \dots 12\% \quad (11)$$

$$V_{crit}^{bending} \approx 0.41 \cdot V_{crit}^{tension} = 0.82\% \dots 4.92\% \quad (12)$$

In this case the value 0.82 % is obtained as the lowest estimate. So it is clear that to have any structural meaning, the fibre content should be near 1 per cent by volume. If the mix proportion of this composite is adjusted, this value will also be changed. On the other hand, the casting became more arduous when the fibre content was increased from 1 % to 1.5 % by volume. This problem can be easily solved by changing the mix proportion. However, this was not under consideration here.

⁸Here the maximum load is the cracking load, because the fibre content is below the critical fibre volume fraction. So comparing this value with this assumed post-crack tensile strength is not reasonable.

CONCLUSION

The fibres increase the fracture load obtained in the tests compared with the load of a flange without reinforcement. With fibre content more than one volume per cent, it is possible to have a higher fracture load than with a normal reinforcement similar to that in the existing beam type. The fracture load can be predicted with simple equations.

With a fibre content of 1.0 volume%, the test structures have visible toughness. It can be assumed that this fibre content exceeds the critical value.

To study the feasibility of fibre-reinforcement, also the toughness and deformation capacity have to be taken into consideration. The role of the flange can be described with following notes:

- The flange is used to support the hollow core slabs. It carries all the loads in the assembly phase, before the slabs are grouted. After that, a certain percentage of the load is transferred to the beam web with dowel action. However, this is not taken into consideration, because there are no practical methods of estimating this.
- The flange is designed only against the flexural load and horizontal load from friction when the slabs are deformed. The amount of reinforcement is small and the flange collapses when the reinforcement yields.
- No analysis for studying the deformations of the flange is carried out. The ductility is assumed to be achieved by using conventional reinforcement.
- There are no requirements for deformation capacity in this particular application. Though it can be said, that the larger the deformations the better.

Fibres are a complicated type of reinforcement although they make the manufacturing easy. The following observations can be made:

- Fibres are situated and oriented randomly in the concrete. Although the test results show only minor deviations, there is still a risk of a poor fibre dispersion.
- Steel fibres are practically always pulled out of concrete, so the fracture occurs due to the poor anchorage of the fibres. Insufficient anchorage is traditionally categorized as a brittle mode of fracture.
- The deflections of flanges become smaller when the fibre content is increased. However, this is not a sign of a poor ductility. It is commonly accepted, that fibres increase the stiffness of a concrete structure at the cracked stage and as a consequence the deflections are smaller.

As a conclusion it can be said that fibres can be used when the following details are solved:

- The fibre content has to be sufficiently high, so that the fibre content exceeds the critical fibre volume-value. The correct fibre content can be ensured by performing a flexural toughness test, for example according to ASTM C 1018.
- Quality control has to be planned in order to maintain constant surveillance of the actual properties of the fibre-reinforced concrete.
- Safety levels have to be studied carefully. A suggestion for a material safety coefficient lies between the values of unreinforced and normally reinforced concrete.

The question of economics is more complicated. In terms of the reinforcing material needed per cubic meter we can say that in the form of dispersed fibres there has to be 30 % more steel than in the form of conventional steel bars. When comparisons were made in co-operation with the manufacturer of the original beam type, it was found that about one per cent by volume is the maximum if the normal reinforcement is done with welded steel mesh. When using separate steel bars this value can be little higher.

ACKNOWLEDGEMENTS

The research presented here was done in a project carried out at the Technical Research Centre of Finland (VTT) with financial support of the Technology Development Centre (TEKES). The research was led by Prof. Asko Sarja. The planning and execution of the studies were co-ordinated by a steering group: Mr Kauko Linna from Lohja Oy Ab (convenor), Olli Korander from Partek Betonila Oy Ab, Mr. Olli-Pekka Nordlund from TEKES and Dr. Seppo Huovinen from Helsinki University of Technology.

Tests with materials as well as the manufacture of test structures took place in the VTT Building Technology under the guidance of Mr. Kai Tattari and Mr. Heikki Iisakkila. Structural tests were carried out by Mr. Heikki Lintunen and Mr. Mats Rundt. Studies concerning the economics of fibre reinforcement were carried out by Mr Olli Korander, Mr. Pekka Häyrynen and Mr. Antti Koponen from Partek Betonila Oy Ab.

LIST OF SYMBOLS

η_ϕ	Orientation efficiency factor of fibres
η_l	Bond efficiency factor of fibres
a, A	Factors
a_l	Loading span
A_s	Cross-sectional area of reinforcement steel
b	Width of a cross-section
d	Effective height of reinforced concrete structure
d_f	Fibre diameter
f_τ	Bond strength between fibres and matrix
f_{ctu}	Ultimate tensile strength of plain concrete
f_{fcbcr}	Flexural first-crack strength of fibre reinforced concrete
f_{fcbu}	Ultimate flexural strength of fibre reinforced concrete
f_{fcr}	Cracking strength of fibre reinforced concrete
f_{fccu}	Ultimate compressive strength of fibre reinforced concrete
f_{fjsp}	Splitting tensile strength of fibre reinforced concrete
f_{fctu}	Ultimate tensile strength of fibre reinforced concrete
f_{fu}	Ultimate tensile strength of fibres
f_{sy}	Yielding strength of steel
h	Height of a cross-section
$I_5 I_{10} I_{20}$	ASTM toughness index
l_{crit}	Critical fibre length

l_f	Fibre length
P_{cr}	Cracking load
P_u	Ultimate load
$R_{N,M}$	ASTM residual strength factor
V_{crit}	Critical fibre volume fraction
V_f	Fibre volume fraction

REFERENCES

1. ASTM C 1018 - 92. Standard test method for flexural toughness and first-crack strength of fiber-reinforced concrete (using beam with third-point loading).
2. Bentur, A. & Mindess, S. Fibre reinforced cementitious composites. London 1990, Elsevier. 449 p.
3. Hannant, D. J., Fibre cements and fibre concretes, John Wiley & Sons, Chichester, 1978, 219 pp
4. Lim, T., Paramsivam, P., Lee, S. Bending behaviour of steel-fiber concrete beams. ACI Structural Journal 84(1987)6 pp 524-536
5. Neville, A. M. Properties of concrete. Pitman, Great Britain 1983
6. Westin, I., Peterson, Ö., Nordin, A., Stålfiberarmerade industrigolv. Stockholm 1992, Cement och Betong institutet, CBI Rapport 6:92, 55 pp

Matti Lanu

M.Sc.(Tech.), Research Scientist

VTT Building Technology

Kivimiehentie 4, Espoo, P. O. Box 1803,

FIN-02044 VTT, Finland

Tel +358 0 4561

Fax +358 0 456 4815

Seppo Huovinen

Ass.prof., Dr. Tech.

Helsinki University of Technology

Rakentajanaukio 4

FIN-02150 ESPOO, Finland

Tel +358 0 451 3718

Fax +358 0 451 3724